

## Company Profile

PROTERIAL COMPANY PROFILE



### Proterial, Ltd.

Toyosu Prime Square, 5-6-36 Toyosu, Koto-ku, Tokyo 135-0061, Japan



#### Safety Precaution

Before using any of the products introduced in this catalog, please read the respective user manuals thoroughly.

The contents of this catalog are subject to change without prior notice.



This Company profile is printed on FSC® certified paper for environmentally friendly printing.

Catalog No. PCC-01EN-202301T  
All rights reserved.

Printed in January 2023

Proterial, Ltd.



# PROTERIAL

## Our Promise

Proterial produces world-class, high-performance materials for mobility, industrial infrastructure, and electronics.

Since 1910, we've brought together specialists of all kinds to improve our skills and technologies, reflecting our commitment to achieve the best possible quality in everything we do. Moving forward, we'll continue to elevate both our products and the processes and people that define them.

Only by conducting all our activities with unfaltering integrity can we meet the expectations and trust of the communities we serve. By creating new and ongoing value, we'll help customers realize innovation and contribute to a sustainable society.

With our professional determination, progressive intent, and proactive approach, we'll strive unceasingly to provide exceptional materials that pave the way to a brighter future.

## INDEX

Corporate Philosophy / The Thinking Behind our Company Name	03
History	05
Proterial's Business Structure and Portfolio	07
Advanced Metals Division	09
Advanced Components and Materials Division	11
Proterial's Core Technologies Supporting a Sustainable Society	13
Automobile-related Field	15
Industrial Infrastructure-related Field	29
Electronics-related Field	45

## Corporate Philosophy

### Mission

#### Make the best quality available to everyone

Striving for the highest standards in our original technologies, products, processes, and people, we will bring new levels of value to customers all around the world.

#### 質の量産

独創的な技術と、製品・ビジネスプロセス・人に関する高い質の追求によって、新たな価値を生み出し、世界の人々に広く提供していく

### Vision

#### Leading sustainability by high performance

Through the creation of best-in-class materials, to be a company that solves individual customer issues and contributes to the prosperity and vitality of all.

#### 持続可能な社会を支える高機能材料会社

お客さまの課題を解決する高機能材料の創造によって、持続可能な社会の実現に貢献し続ける企業となる

### Values

#### Unflinching integrity

We earn the trust of our customers and other stakeholders by being honest and sincere in our daily activities and by understanding our obligation to the people and communities we serve.

#### 至誠

人や社会に対する責任を常に自覚し、日々のあらゆる活動に誠実に向き合う。約束を守る、正直に行動することを徹底し、私たちに関わる全ての人々の信頼と期待に応える

#### United by respect

Across our organization, we respect diversity and the free and independent exchange of opinions, learn from each other, and collaborate to achieve our common goal.

#### 和すれば強し 鯨則彊

多様な個を尊重し、主体性をもって自由に意見を交わし合い、学び合い、共通の目的に向けてチーム全員の情熱と能力を結集することで成果を出す

## The Thinking Behind our Company Name

# PROTERIAL

“Proterial” reflects the essence of our Corporate Philosophy. It combines “pro-” with the word “material.”

“Pro-” represents our “three pros”:

- Professional – work that exceeds expectations
- Progressive – a spirit that keeps challenging
- Proactive – an enterprising attitude

“Material” refers to the high-performance materials that our original technologies produce and underpinned by the three pros.

With our focus on solving customer issues and bringing new levels of value, we promise to contribute to the realization of a sustainable society through the products and services that embody our philosophy.

Our logo uses a typeface that expresses simplicity, power, and dignity. Its navy blue treatment suggests calmness and depth.

# History

Over our more than 100-year history, the Proterial Group has continued to grow through a succession of process, we created the diverse technologies, products, and business portfolios that are the source of our embodiment of “Proterial’s uniqueness.” Operating in the field of materials, which is undergoing drastic strengthen the diversity that we have cultivated throughout our history, to continue to be a company that is

mergers and acquisitions. Through this competitiveness, and this diversity is the technological change, we will build on and indispensable to customers and society.

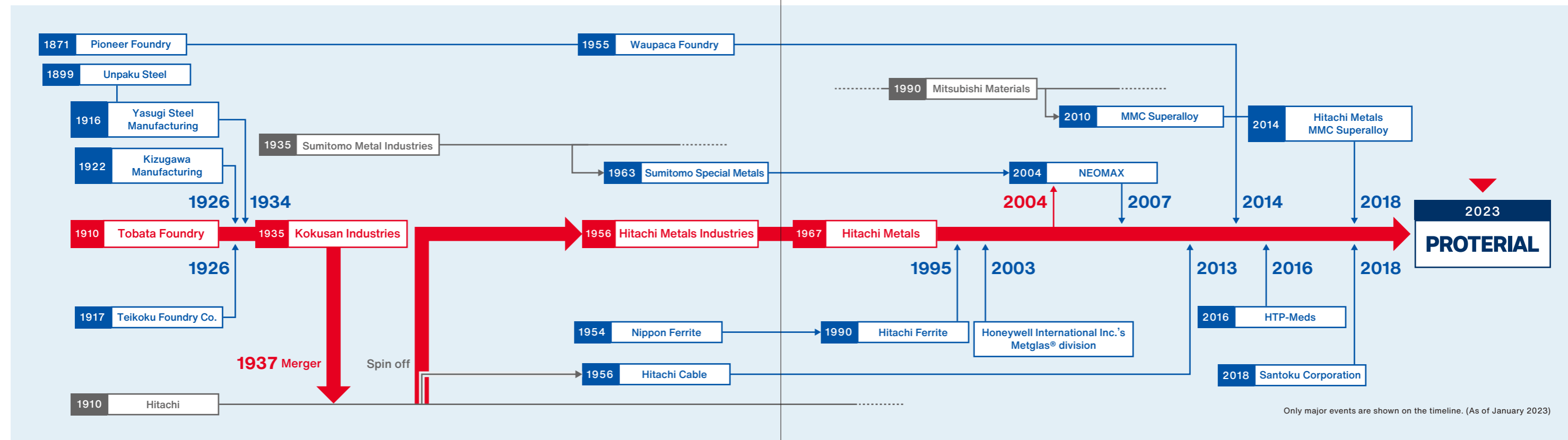

## 1910 Tobata Foundry

At a time when a modernizing Japan relied on imports for almost all of its industrial goods, Yoshisuke Ayukawa acquired malleable cast iron manufacturing technology and established Tobata Foundry, the predecessor of our company. In 1911, the company began manufacturing Gourd brand-black heart malleable cast iron pipe joints. The company later began to produce products for other uses including shipbuilding, railways, and spinning machines, and orders grew steadily as the superior quality of these products was recognized. Business areas were diversified through mergers with Teikoku Foundry, which at the time was producing steel for steel rolling, Kizugawa Manufacturing, a producer of fittings, and steelmaker Yasugi Steel Manufacturing.

## 1935 Kokusan Industries

As the business expanded to cover heavy industries in general, Tobata Foundry changed its name to Kokusan Industries.

## 1956 Hitachi Metals Industries

Hitachi transferred its metals business with five originally Tobata Foundry plants (Tobata, Fukagawa, Kuwana, Wakamatsu, and Yasugi) to establish Hitachi Metals Industries.

## 1967 Hitachi Metals

Hitachi Metals Industries changed its name to Hitachi Metals. Through creative monozukuri and proactive mergers and acquisitions, the Company went through a succession of changes and grew to become one of the world’s leading materials manufacturers. Today, the Company provides technologies and services that are contributing to the shift in automobiles to electric vehicles, and advances in industry, infrastructure, and electronics around the world.

## 1995 Hitachi Ferrite

Merged with Hitachi Ferrite in 1995 to strengthen the soft magnetic materials business in response to increased demand for noise reduction in automobiles and electronics.

## 2003 Honeywell International Inc.’s Metglas® division

Acquired the Metglas® (amorphous metal materials) division of Honeywell International of the United States. Strengthened the soft magnetic materials division as demand in the electronics segment grew for size and weight reductions, energy conservation, and electromagnetic noise reduction.

## 2007 NEOMAX

Established through the merger of the magnetic materials and applications operations of Hitachi Metals and Sumitomo Special Metals to manufacture high-performance neodymium magnets and ferrite magnets widely used in motors for automotive equipment and home appliances. With demand for automotive-use motors expected to grow, the merger was carried out in 2007 to integrate the magnetic materials businesses and increase synergies.

## 2013 Hitachi Cable

Merged with Hitachi Cable, the Hitachi Group’s electric wires and cable business, in 2013. As the pace of movement toward a low-carbon society accelerated, the merger was intended to create synergies in terms of technologies and sales in the automotive, electronics, and industrial infrastructure segments.

## 2014 Waupaca Foundry

Made Waupaca Foundry, the world’s largest manufacturer of automotive-use castings with an overwhelming share of the U.S. market, a subsidiary in 2014. Expanded our business to become the world’s largest supplier of iron castings.

## 2014 Hitachi Metals MMC Superalloy

Made MMC Superalloy, with extensive experience and technological capabilities in aircraft parts, a subsidiary with a view toward global growth in core industries including aircraft and energy. Hitachi Metals’ Okegawa Works established in April 2018.

## 2016 HTP-Meds

In line with the aim of strengthening our operations in the medical field and achieving medium- to long-term global growth, HTP-Meds was made a subsidiary. An operator of the medical tubing business in the U.S., the company was merged with Hitachi Cable America in April 2018.

## 2018 Santoku Corporation





















Santoku became a consolidated subsidiary of Hitachi Metals as an effort to strengthen our production system for neodymium magnets and to optimize the material flow from raw materials to finished products.

## 2023 Proterial

Hitachi Metals changed its name to Proterial. Through the creation of best-in-class materials, to be a company that solves individual customer issues and contributes to the prosperity and vitality of all.

# Proterial's Business Structure and Portfolio

The Proterial Group is a material manufacturer with highly competitive core technologies for high-performance materials. With the world's top brands in its portfolio, Proterial engages in a broad range of businesses in the markets related to industrial infrastructure, automobiles, and electronics.

		Automobile-related Field	Industrial Infrastructure-related Field	Electronics-related Field	
Advanced Metals Division	<b>Specialty Steel</b> Molds and tool steel, Automobile-related materials, Razor and blade materials, Precision cast components, and Aircraft- and energy-related materials, Display-related materials, Semiconductor and other package materials, and Battery-related materials	 CVT Belt Materials	 DAC-i™ the Next-generation Hot Working Tool Steel	 Specialty Steel  Turbine Case	 Clad Materials  Lead Frame Materials
	<b>Roll</b> Rolls for steel mills, Injection molding machine parts, Structural ceramic products, and Steel-frame joints for construction		 HINEX™ Rolls for Iron and Steel Rolling	 Roll  Cylinders and Screws for Plastic Molding Machines	
	<b>Automotive Casting</b> HNM™ high-grade ductile cast iron products, Cast iron products for transportation equipment, HERCUNITE™ heat-resistant exhaust casting components, and Aluminum components	 High-toughness Ductile Cast Iron Products	 HERCUNITE™ Series of Heat-Resistant Cast Components		
	<b>Piping Components</b> Piping and infrastructure components (Gourd brand pipe fittings, valves, stainless steel and plastic piping components, water cooling equipment, precision mass flow control devices and sealed expansion tanks)			 Pipe Fittings for General Use	 Polyethylene Gas Piping Systems
Advanced Components and Materials Division	<b>Magnetic Materials</b> NEOMAX™ rare-earth magnets, Ferrite magnets, and Other magnets and applied products	 Neodymium Magnets NEOMAX™ Series		 Magnetic Materials Ferrite Magnets NMF™ Series	
	<b>Power Electronics Materials</b> Soft magnetic materials (Metglas™ amorphous metals; FINEMET™ nanocrystalline magnetic material; and soft ferrite) and applied products, and Ceramic components		 FINEMET™ Nanocrystalline Magnetic Alloys	 Power Electronics Materials Soft Ferrite Cores	
	<b>Electric Wire &amp; Cable</b> Industrial cables, Electronic wires, Electric equipment materials, and Cable assemblies	 Wires and Cables for Rolling Stock		 Electric Wire & Cable Industrial Robot Cables	
	<b>Automotive Components</b> Electronic components for automotive, and Brake hoses	 Automotive Components Harness for Electric Parking Brakes			

# Advanced Metals Division

Our steel manufacture and casting technologies draw upon over a century of tradition. It is into this tradition that we weave innovative concepts.

We add innovative concepts to existing foundational technologies stemming from the tradition - namely, steel manufacture technologies such as YASUGI SPECIALTY STEEL, and the casting technologies, which have yielded our proprietary Gourd brand  pipe fitting products- to develop cutting-edge metal materials. Our products are extensively used in different industrial sectors. Beyond core industrial sectors including automobile and industrial infrastructure, they have penetrated into the fast-growing industries such as those of aircraft and energy sectors.

With world-class capabilities for the development of materials and products, as well as production scale and sales system that leverage our global network, we are able to promptly and accurately provide products to match needs arising in the markets of different countries worldwide.

## Specialty Steel A history of innovation in advanced metallurgical technology and materials development

As can be seen in "Tamahagane" produced by the ancient iron-making method "Tatara", with our material development capability in producing high purity steel by using selected raw material and traditional steel manufacturing technology, we provide a wide range of high functional materials to support the development of industries.



DAC-i™ the Next-generation Hot Working Tool Steel



Clad Materials



CVT Belt Materials



Turbine Case

## Roll Advanced roll technological capabilities

In addition to our leading brand of HINEX™ rolls for steel mills, we offer cylinders for injection molding machines and the processing of structural and other components for construction.



HINEX™ Rolls for Iron and Steel Rolling



Cylinders and Screws for Plastic Molding Machines

## Automotive Casting Global development of eco-friendly products

Drawing on its roots that date back to Tobata Foundry Co., Proterial has applied malleable cast iron manufacturing technologies to produce casting components for automobiles. In recent years, we have developed HERCUNITE™ heat-resistant exhaust casting components and been striving to meet the growing need for products helpful in reducing environmental load.





High-toughness Ductile Cast Iron Products



HERCUNITE™ Series of Heat-Resistant Cast Components

## Piping Components Development of (Gourd brand) gas and water piping components

When the Tobata Foundry Co., the forerunner of Proterial, shipped its first product in 1910, it bore a  (Gourd) symbol. This symbol bore the hopes and aspirations that products would be "tougher, smoother, and aesthetically pleasing." Since this time, the Gourd brand has been widely used in industrial and household fields, as well as overseas markets. Today, the  (Gourd brand) is well respected throughout the world.



Pipe Fittings for General Use



Polyethylene Gas Piping Systems

# Advanced Components and Materials Division

We deepen new material development and our unique innovative part design technology capabilities to bring unique products into existence.

We have developed NEOMAX®, world-class neodymium magnet, and Metglas®, amorphous metal material with excellent soft magnetic properties. The functional members with specific characteristics have been integrated into xEVs\* to support their progress.

In addition, our products with different capability of improving environmental performance and energy efficiency support industrial infrastructure sectors, including railway, medical devices, and industrial robots.

We combine our proprietary materials and technologies to develop advanced products.

\*Term referring to electric vehicles (EV), hybrid electric vehicles (HEV), and plug-in hybrid electric vehicles (PHEV).

## Magnetic Materials NEOMAX® brand, key material for industries

We boast an extensive magnet range, which includes NEOMAX® rare earth magnets and ferrite magnets, and provide our products across a wide range of fields, encompassing automobiles, electronics and home appliances. As pioneers in the field of magnetic materials, we take on the challenge of new materials and new production technologies, meeting our customers' diverse needs and contributing to the creation of a more energy-efficient society.

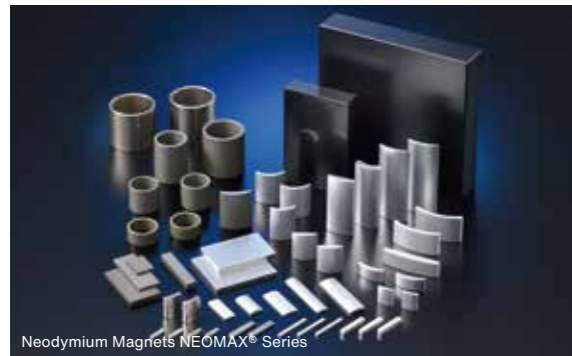

Neodymium Magnets NEOMAX® Series

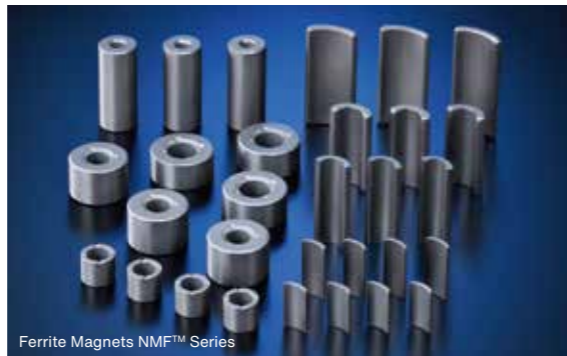

Ferrite Magnets NMF™ Series

## Power Electronics Materials Our advanced soft magnetic and ceramic materials contribute to energy conservation and ICT innovations

We contribute to the downsizing and energy efficiency of devices with products that offer distinctive features, including MaDC-A™ magnetic domain control type Fe-base amorphous metal, MaDC-F™ magnetic domain control type high-performance soft ferrites, FINEMET® nanocrystalline materials, and high-performance ceramics.



FINEMET® Nanocrystalline Magnetic Alloys

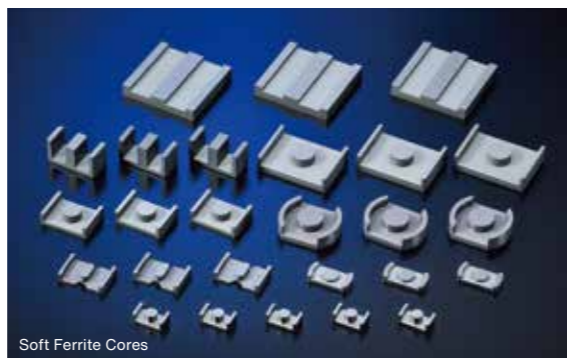

Soft Ferrite Cores

## Electric Wire & Cable Contribute to more sophisticated social infrastructure

We develop and offer wires and cables for rolling stock and railroad infrastructure, medical and electronic devices, electrical appliances and automobiles. We meet our customers' needs for more compact and high-performance devices making use of our technological strengths and know-how to transfer energy and transmit information efficiently and quickly.

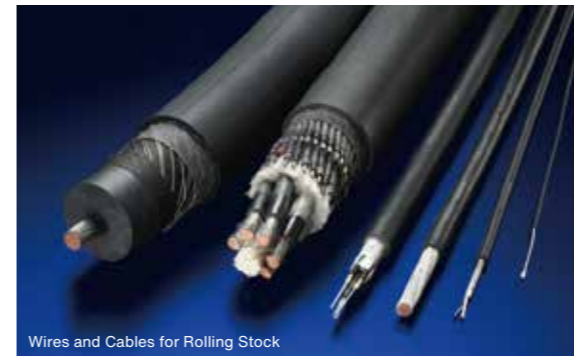

Wires and Cables for Rolling Stock



Industrial Robot Cables

## Automotive Components We address today's needs for ever greater safety, energy efficiency, and convenience

Our sensors, power harnesses, and brake harnesses and hoses are all developed and manufactured to provide efficient and reliable energy and signal transmission. They are supported by a global supply system that encompasses production, marketing, and quality assurance to satisfy a diverse range of customer needs.



Harness for Electric Parking Brakes



Brake Hoses

# Proterial's Core Technologies Supporting a Sustainable Society

Proterial delivers solutions to issues facing society with its advanced microstructure control technology and design technology for advanced components and materials, which have been developed over its more than 100-year history.

## Advanced Microstructure Control Technology

Our advanced microstructure control technology has been derived and evolved from structural control technology, alloy design technology, and production technology in the specialty steel field and the functional components and equipment field. Day by day, we advance our long-accumulated expertise with state-of-the-art techniques, such as materials analysis aided by artificial intelligence (AI). This enables us to speedily optimize the effects of melting, casting, sintering, forging, and other manufacturing processes to get the best out of materials. A typical field of application is additive manufacturing, which has recently become a booming industry. In addition to our proprietary super corrosion-resistant alloys, we offer structural control technology and modeling technology that can combine structural complexity and high corrosion resistance to help customers resolve their challenges.

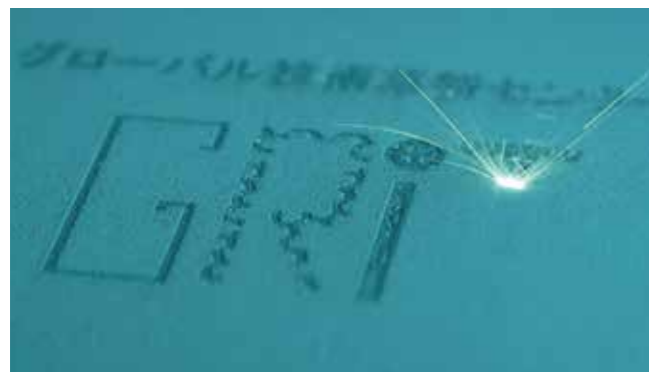

Additive manufacturing

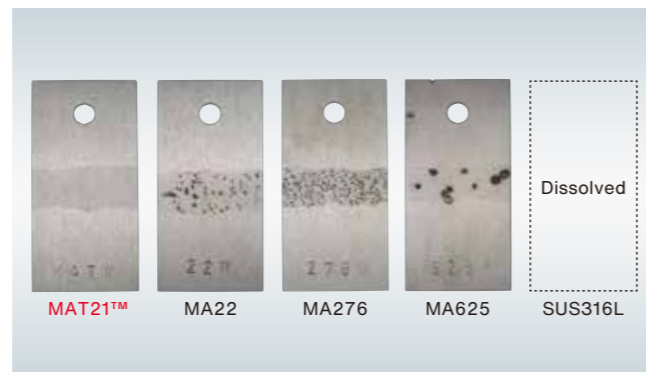

Example of pitting corrosion resistance test results for Proterial's corrosion-resistant material 24 hours at boiling temperature (104° C) in 11.5% H<sub>2</sub>SO<sub>4</sub> + 1.2% HCl + 1% FeCl<sub>3</sub> + 1% CuCl<sub>2</sub>

## Design Technology for Advanced Components and Materials

Our design technology for advanced components and materials enables us to produce magnetic materials, power electronics materials, electric wire and cable materials, and many other components and materials with distinctive features. We closely communicate with customers and propose solutions to their problems by integrating our original composite dispersion control technology and processing technology for high-performance materials with leading-edge technologies like materials informatics. Proterial delivers advanced components and materials that meet the needs of different sectors. Our products help make vehicles more efficient, compact, and lightweight in the xEV field, where rapid growth is expected; enhance safety and workability in the globally developing rail sector; and achieve higher resolution and reduce the burden on patients in the ever-advancing healthcare field.

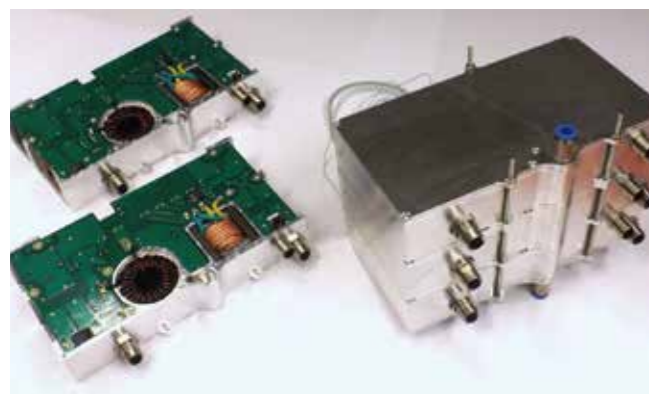

On-board charger that combines higher output and smaller size

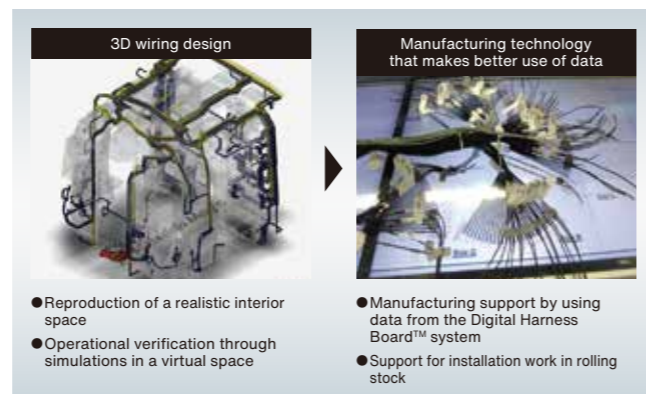

Rolling stock wire harness solutions based on digital twin technology

## Research & Development Structure

The Global Research & Innovative Technology center (GRIT) is a Corporate Research Lab of Proterial. It was established to promote research on advanced materials over the medium to long term and future-oriented process research with a view to achieving sustainable growth and making social contributions. We are witnessing huge waves of change that will dramatically alter our society. These include a major transformation in production systems, which is fueled by the development of the Internet of Things (IoT), as well as a shift from gasoline-powered vehicles to electric vehicles. GRIT is poised to respond to these rapid changes by creating new products and businesses that take potential threats and opportunities into consideration. To this end, open innovation will be pursued together with research institutes, universities, and corporations in Japan and abroad. Our division labs, which are research centers operated by individual business divisions, are also eager to develop products directly connected to their respective business domains through down-to-earth R&D activities.

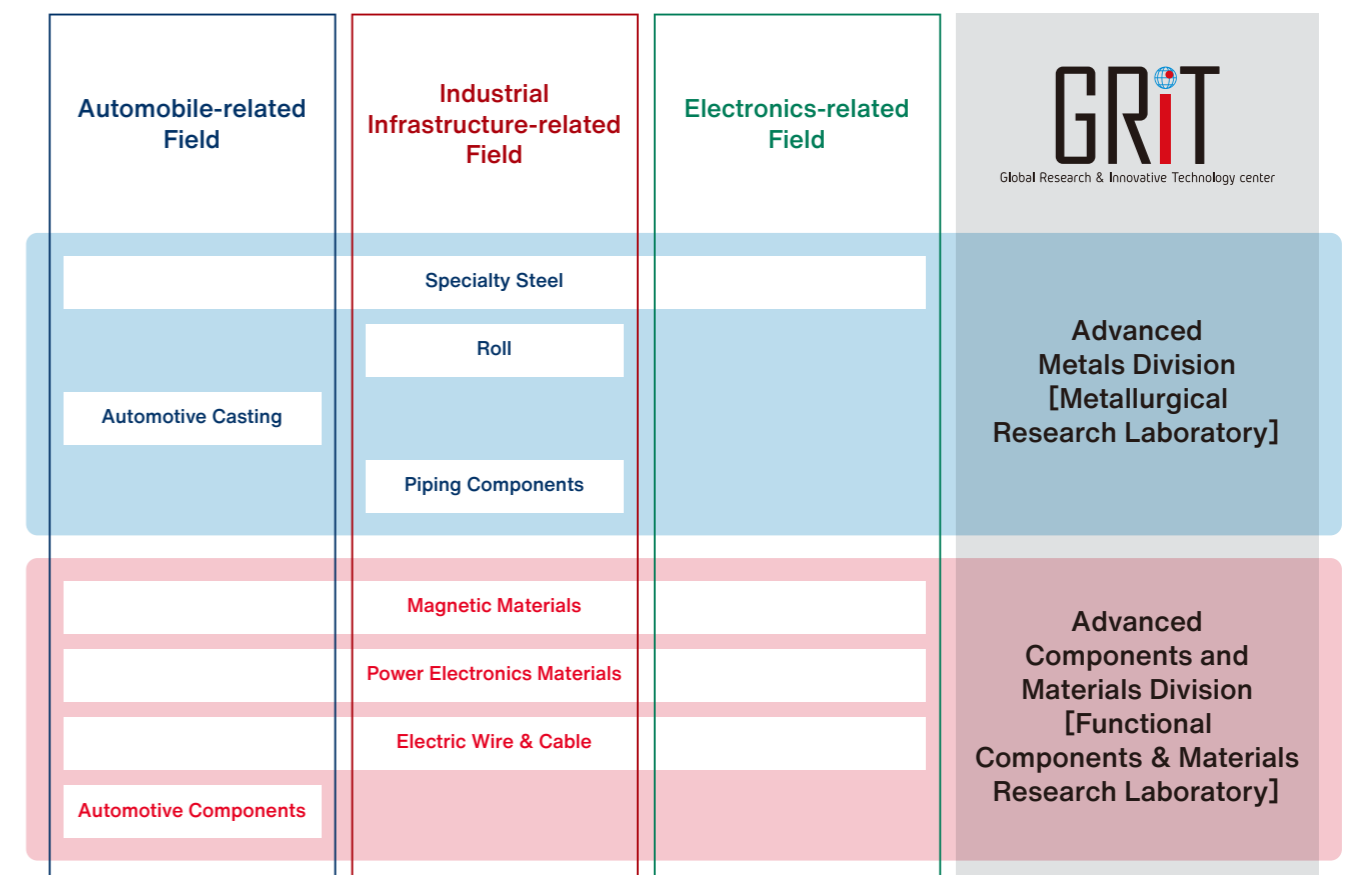



# AUTOMOBILE

## Automobile-related Field

Proliferating eco cars and improving fuel economy and safety performance

- We appropriately capture changes in environmental performance required for automobiles, thus relentlessly pursuing the evolution of all of our products. Ranging from drive motor components and exhaust system components to chassis components
- We use our development and technological capabilities to support automobile manufacturing around the world.



◀ Related link

## xEV (for Motor)

Our magnets, soft magnetic components and materials, enameled wires, and other unique products support the evolution of xEV motors.

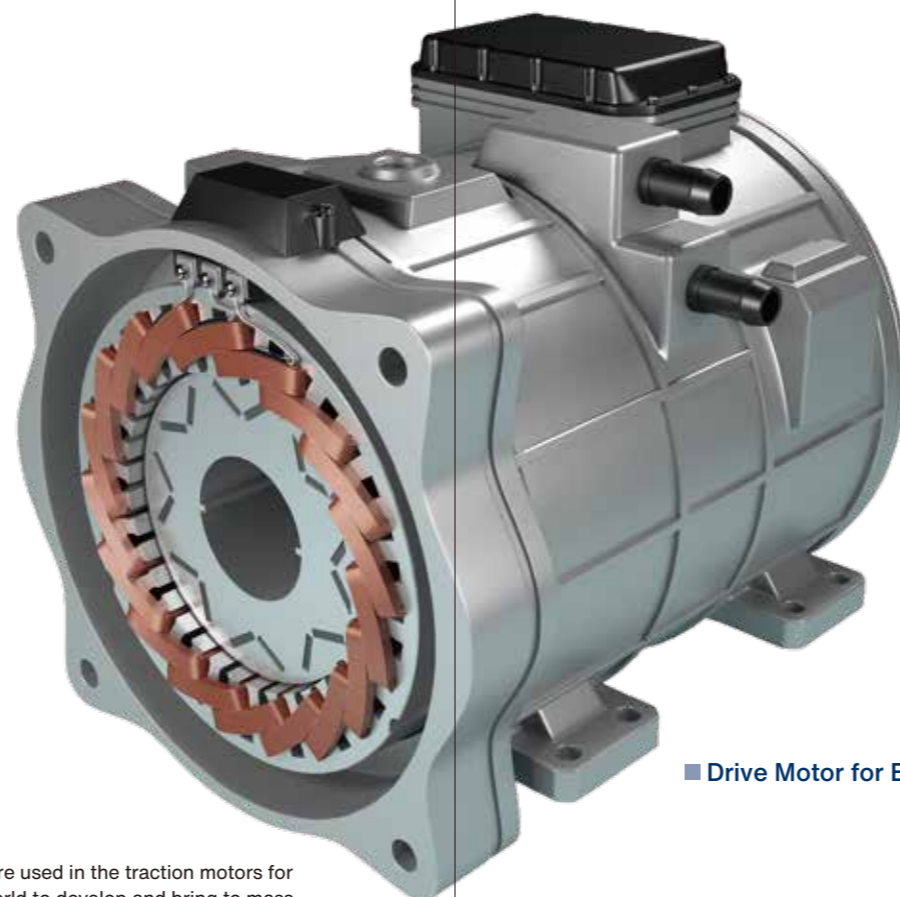

■ Drive Motor for EV

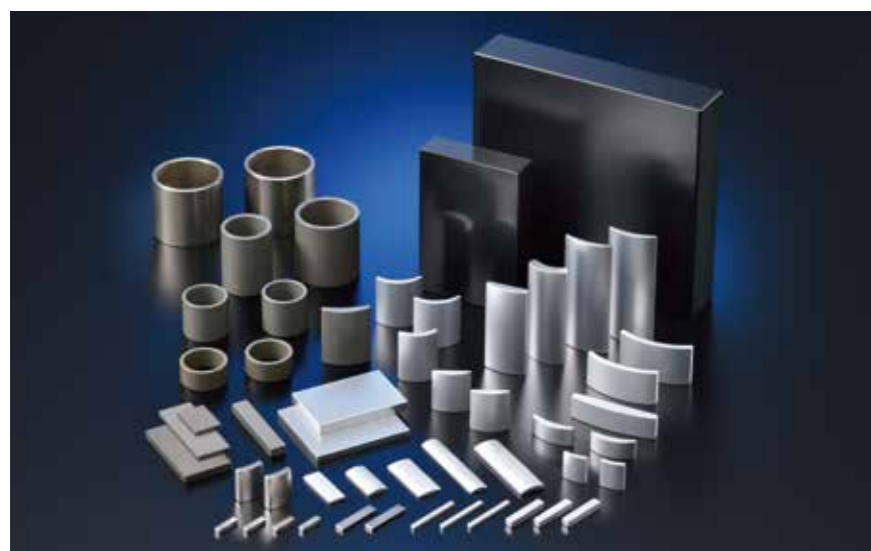

### Neodymium Magnets NEOMAX® Series

These Nd-Fe-B (neodymium-iron-boron) sintered magnets provide the highest level magnetic properties and are used in the traction motors for electric and hybrid vehicles as well as for other applications. NEOMAX®—which Proterial was the first in the world to develop and bring to mass production—withstands a broad range of environmental conditions from room temperature to much higher temperatures around engines. In addition, we have been developing magnets that use less heavy rare earth. These environmentally friendly products with superior magnetic properties contribute to smaller size, lighter weight, and better efficiency for our customers. We are still accelerating the development of magnets that use much less heavy rare earth and expanding product lineups to meet our customers' needs.

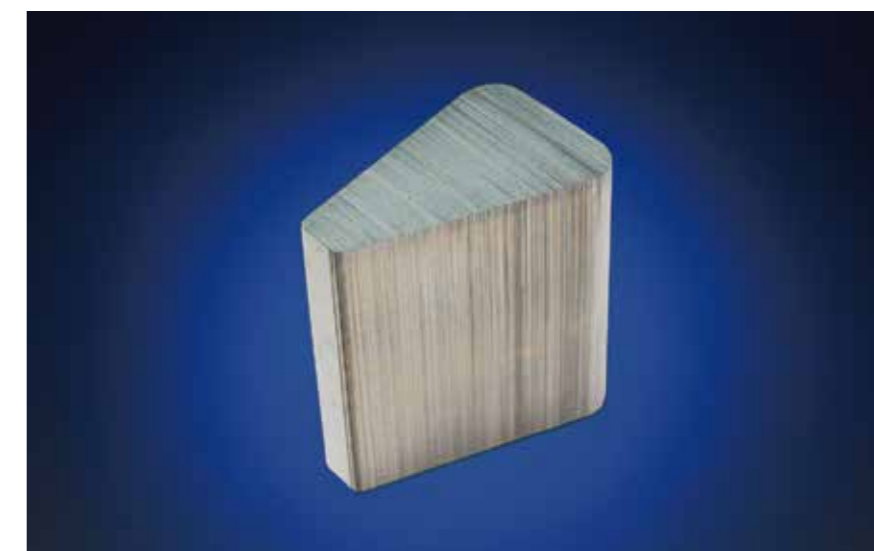

### Amorphous Soft Magnetic Alloy for Motors

Amorphous soft magnetic alloy is prominent core materials for use in next-generation high-efficiency motors. With about one-tenth the iron loss of non-oriented magnetic steel sheets, these materials contribute to core loss reduction in motors.

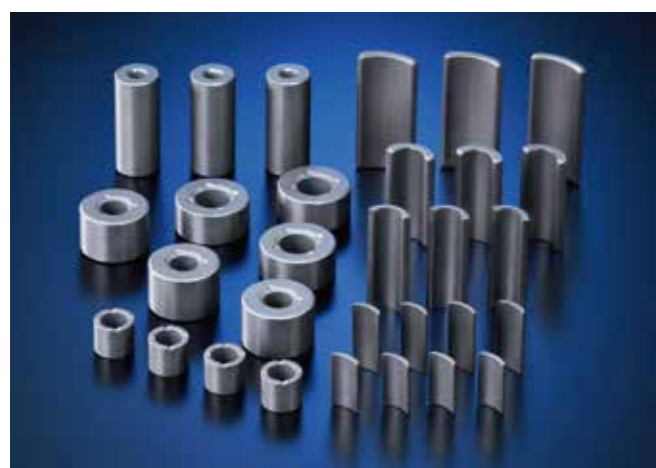

### NMF™ series ferrite magnets

Ferrite magnets, which consist primarily of iron oxide, are cost effective and the most widely used magnets in motors for automotive electrical components. Among the NMF™ series, NMF-15 is the world's leading mass-produced ferrite magnet in terms of magnetic properties. Their excellent magnetic properties make them ideal for a wide range of applications including motors for power windows, power seats, sunroofs, cooling fans, and windshield wipers.



### Ultrahigh Density Bonded Magnets HIDENSE™ Series

The HIDENSE™ is a high-performance bonded magnet developed with the high-compression technology. This magnet is highly flexible in shape and magnetization and can be integrated with metal components, thus contributing to a wide range of product designs.



### Enamelled Wires for High-Efficiency Motors

This wire product supports the compact design and higher outputs required for electric and hybrid vehicles while reducing environmental impact and saving energy, leading to the development of higher-performance electric and hybrid vehicles.



### Aluminum Motor Housings Containing EV/HEV Components

These Aluminum casting housings are manufactured by high pressure die cast or low pressure casting processes. They help make the motors smaller, lighter, and more powerful because of optimized high-strength material. Being castings, realizes a high degree of freedom cooling circuit and contributes to maximizing cooling characteristics.

# xEV (for Inverter, On-board Charger, etc.)

We offer products with distinctive features, including energy saving, noise reduction, vehicle downsizing, and weight reduction, thereby accelerating the electrification of automobiles.



## FINEMET® Nanocrystalline Magnetic Alloys

FINEMET® is the world's first nanocrystalline soft magnetic alloy developed by Proterial. This new Fe-based soft magnetic alloy is composed of nanocrystals. It has high saturation induction, high permeability, excellent temperature characteristics and temporal stability. FINEMET® is utilized in high-frequency power transformers, noise-suppression components and other applications where it contributes to downsizing and lightening.



## FINEMET® Common Mode Choke Cores and Coils

Instilled with high magnetic permeability and low Q factors, these cores and coils furnish high impedance over a broad frequency range, allowing them to manifest major noise suppression effects. Moreover, because impedance does not vary widely by temperature, stable noise suppression effects can be obtained over a broad temperature range.



## Soft Ferrite Cores

Although these cores have a lower saturation flux density than other soft magnetic materials, their electrical resistance is higher, and they are characterized by overwhelmingly excellent magnetic properties in high-frequency bands from 100 kHz to several tens of MHz. With the addition of the MaDC-F™ series, which have low losses in the high-frequency range, these products help to make passive components smaller, lighter, and more efficient in many fields, including xEV, mobile devices, and industrial equipment.

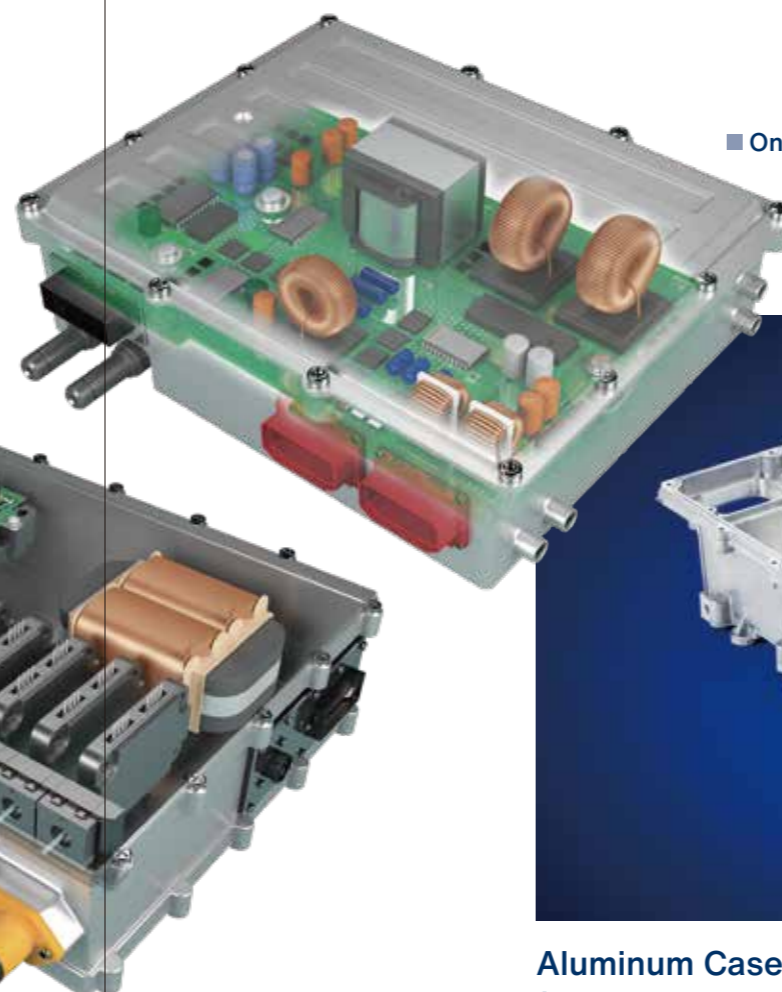

■ On-board Charger



## Aluminum Cases Containing EV/HEV Components (Battery and Inverter)

These Aluminum cast cases are manufactured by a gravity die casting processes. They help reduce the weights of the Battery unit because of their material composition and higher freedom in shaping. And the cases may accommodate any water-cooling circuits, which helps contributes to maximizing cooling characteristics.

■ Inverter



## Amorphous Powder Cores/Coils

These cores and coils are designed to combine high saturation flux density and low loss by using a Fe-based amorphous metal powder. They are suitable for smoothing choke coils for both input and output of power supply, choke coils for normal-mode noise reduction, and choke coils for power factor correction circuits. The coils are able to operate at frequencies as high as 100 kHz and contribute to making equipment smaller and more efficient.



Reactor



## Isolating Transformers

These transformers use ferrite cores that are less likely to saturate during high-temperature operation and employ our original isolating structure to achieve high dielectric strength and a compact body.

## xEV (for Power Module)

We contribute to enhancing the performance of power modules with highly thermal-conductive components and technologies conducive to improving the quality of next-generation power semiconductors.

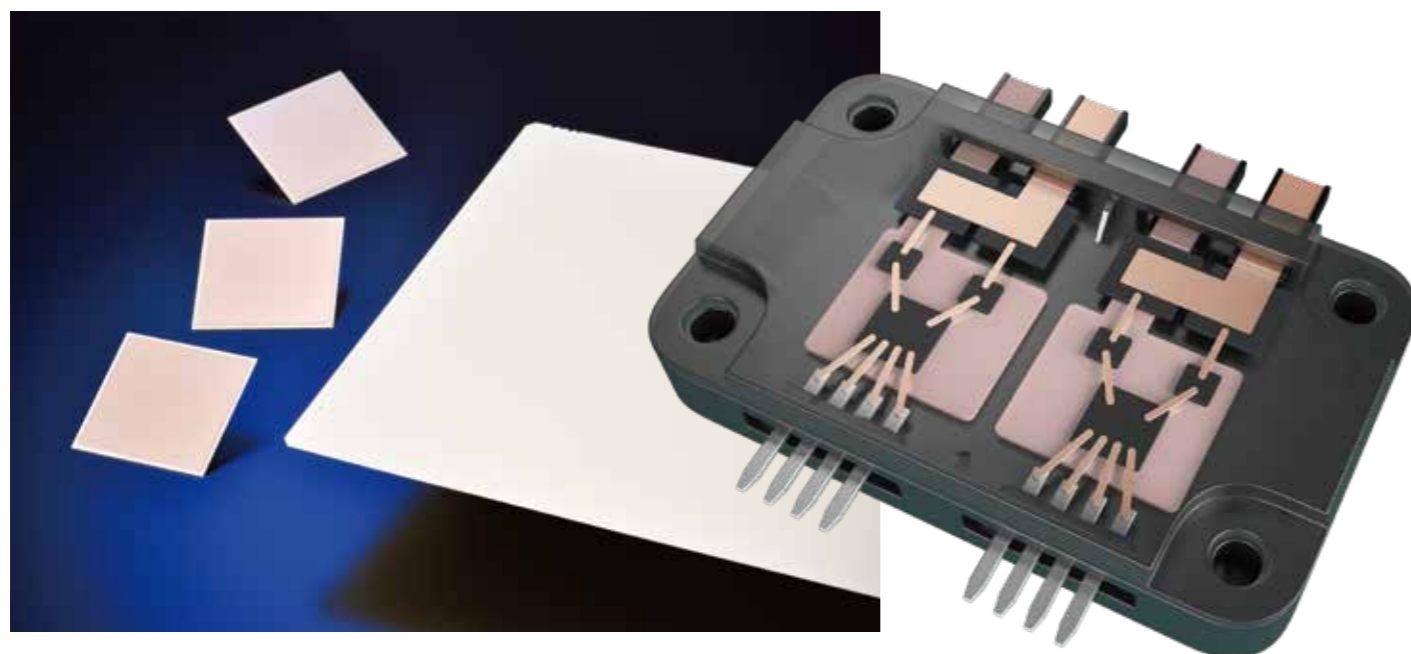

### Si<sub>3</sub>N<sub>4</sub> Insulating Substrates for Power Semiconductor Modules

■ Power Module

Our insulating substrates are used in power semiconductor modules for inverters in hybrid and electric vehicles. Because of their superb heat conduction and mechanical strength, Proterial' silicon nitride substrates are best suited as insulated substrates for large power semiconductors that require high reliability, including insulated gate bipolar transistors (IGBT) and silicon carbide (SiC) devices. Our product lineup also includes 130W/mK substrates to support reductions in thermal resistance.



### SiC Wafers for Power Semiconductors

We undertake SiC power semiconductor wafer production processes with Hi-LoDe Lap™, which harnesses our ceramic material polishing technologies accumulated over the years, and Hi-LoDe Epi™, which is aimed at reducing defects.



### Copper Alloy Strips, Dual Gauge Copper Strips

Copper strips with outstanding thermal conductivity and heat resistance are available. Our dual gauge copper strips, which integrate thin plate and thick plate into a single structure, enhance the heat dissipation in power semiconductor modules for automobiles.



### Clad Metals

Developed according to our proprietary technology, these clad metals feature low thermal expansion and high thermal conductivity. They are best-suited for heat-dissipating substrates of power semiconductor modules and lead wires for power semiconductors.

## xEV (for Battery)

Contributing to the weight reduction, downsizing, and capacity increase of batteries.



### Clad Foils for Lithium Ion Battery's Power Collector

Our rolled clad foils, which are made of Ni alloy and Cu, contribute to achieving electric characteristics required for power-collecting foils and increasing the strength of power-collector.



■ Battery



### Aluminum Cases Containing EV/HEV Components (Battery and Inverter)

These Aluminum cast cases are manufactured by a gravity die casting processes. They help reduce the weights of the Battery unit because of their material composition and higher freedom in shaping. And the cases may accommodate any water-cooling circuits, which helps contributes to maximizing cooling characteristics.

## xEV (for Rapid Charger)

Our products contribute to reducing charging losses and making chargers smaller and lighter.

■ Rapid Charger



### FINEMET® Cut Cores for High-frequency Transformers FINEMET® Non-Cut Cores for High-frequency Transformers

FINEMET® nanocrystalline soft magnetic materials have far lower core losses than magnetic steel sheets, rendering them suitable as core materials for isolating transformers operating at high frequencies of 5 to 20 kHz. They contribute to equipment downsizing when used in isolating transformers for inverters, typically those in rapid chargers.



# Engine and Exhaust System-related Components

Using our alloy design techniques cultivated in the specialty steel field and our casting techniques refined in the long history of the company to produce heat-resistant components that meet needs.



## Piston Ring Materials

Proterial offers a wide variety of materials that cater to the needs of advanced engines and manufactures near-net-shape wire materials to achieve optimal ring shape. Through high-mix, low-volume production adaptable to customers' needs, we can deliver pre-hardened ring materials excellent in performance and precision.



## Engine Valve Materials

Designed for use in exhaust engine valves that can help reduce engine emissions, these materials are exceptionally resistant to high temperatures and high-temperature fatigue, based on our technology. These products contribute to cost reduction with nickel saving compared to conventional heat resistant steel.

## Others

Other products we provide include materials for fuel injection systems, spark plugs, sintered strip, semiconductor producing equipment material, bearing materials, etc.



## Ni-based Amorphous Brazing Foils

This amorphous brazing foil is primarily made of nickel and copper. It has low environmental impact because it does not contain organic binders. Being thin and resistant to corrosion, the material is suitable for the brazing of heat exchangers.

**Metglas**



## HERCUNITE™\* Series of Heat-Resistant Cast Components

This series of heat-resistant cast-steel/cast-iron product helps reduce CO<sub>2</sub> emissions and fuel consumption in gas engine vehicles etc. The products are applied in turbine housings, exhaust manifolds and other exhaust system. They are able to withstand the extreme heat generated by an internal combustion engine and contribute to improving a car's environmental performance.

\*The origin of the name HERCUNITE™  
The name HERCUNITE is an acronym for HEat Resisting Cast materials for UNIT of Exhaust parts. However, the name has another derivation. The suffix nite, which stands for a metal compound, is preceded by the name Hercules, a hero in Greek mythology.



## Turbine Wheels for Turbochargers

These products are made of nickel-based heat-resistant super alloy that exhibits superior resistance to heat. Investment casting is employed to produce complicated three-dimensional components through near-net-shape forming.

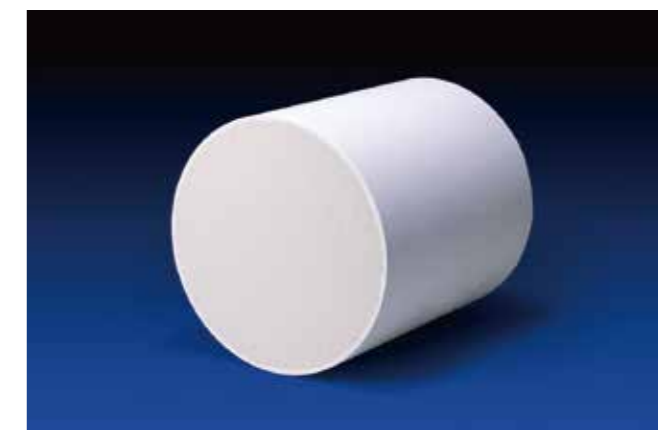

## Diesel Particulate Filter

Proterial's Diesel Particulate Filters are honey comb structured cordierite ceramics filter developed for an after treatment device of medium and heavy duty trucks and buses which can remove PM\* efficiently from exhaust gas from diesel engines.

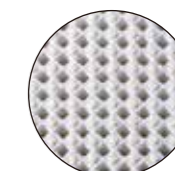

Close-up Cross-section

※PM: Particulate Matters

## Steering System and Powertrain-related Components

Developing high-quality metal materials and various magnetic materials that are essential for CVTs (continuously variable transmission), electric power steering systems, and transmissions.



### CVT Belt Materials

Maraging steel belt materials developed for the continuously variable transmission (CVT), which is a major contributor to a fuel-efficient engine. Based on metallographic innovations, we have developed thin cold-rolled materials with world-class fatigue strength that contribute to upgraded transmission performance and increased reliability.

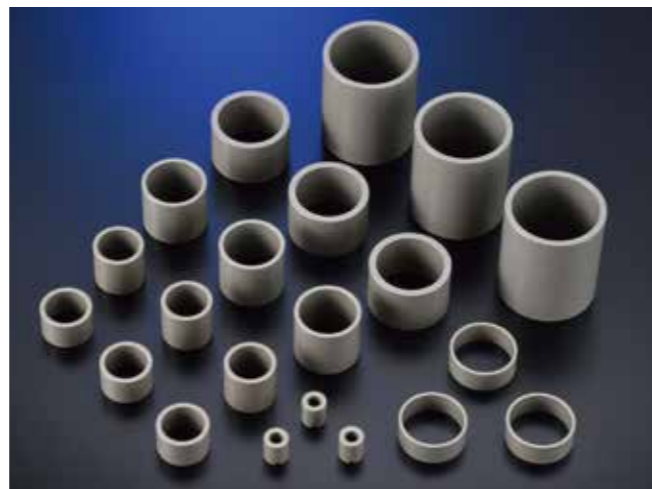

### NEOMAX® Series Neodymium Magnets / Radially Anisotropic Ring Magnets

At Proterial, we not only support typical block and arc-shaped magnets, but also radially anisotropic ring magnets that have a radial anisotropy direction. These magnets provide a high degree of freedom in setting the number of poles, and can also be magnetized at a skewed angle relative to the axis of rotation (skewed magnetization) to reduce cogging torque (rotation unevenness). They are used in electric power steering (EPS) and exhaust gas recirculation (EGR) systems, which require downsizing and better efficiency, as well as in servo motors for power tools and factory automation.



### Cast Iron Products for Automobiles (Transmission Cases for Commercial Vehicles and Clutch Housings for Off-highway Vehicles)

Waupaca Foundry, Inc. is the world's largest foundry of iron castings, providing a wide variety of products for use in items ranging from passenger cars, commercial vehicles to construction and off-highway vehicles. Waupaca Foundry's iron castings are superior in dimensional accuracy, and can be delivered to customers in a near-net-shape state, thus contributing to the production of weight reduction, thinner-walled components.

## Chassis-related Components

Continuing to pursue best suited materials, shapes, and manufacturing techniques, thereby reducing weight, increasing fuel economy, and improving safety.



### High-toughness Ductile Cast Iron Products HNM™ and NMS™

Our ductile cast iron products exhibit high toughness at low temperature and high dimensional accuracy. Our products come in a wide variety of materials and sizes to support broad applications worldwide, ranging from small passenger cars to large commercial vehicles. By capitalizing on high-precision CAE techniques, we have developed new products that can help make automobiles even lighter. A notable example is OMEGA KNUCKLE™, which employs a new structural design that is a lightweight, thin-walled, and half-hollow shape with strength.



### Harness for Electric Parking Brakes

We developed harnesses for use in electric parking brakes that excel in flexural resistance and durability. Their high integrability with the ABS sensor harness allows effective space conservation inside the cabin and increases vehicle safety and convenience.



### Brake Hoses

brake hoses have been widely acclaimed and are used by the world's leading automakers.

# Manufacturing Facilities

Developing materials for manufacturing facilities, including flexibly processable and highly durable steel for tools, according to needs, thereby contributing to the improvement of production efficiency.



## DAC-i™ Steel for the Next-generation Standard Die-casting Dies

Compared to generic JIS SKD61, and DAC, our general-purpose steel for die-casting dies, this general-purpose steel is superior in high-temperature strength and ductility. In addition to our proprietary alloy composition and structure control technology, a 10,000-ton-class free forging press introduced to our Yasugi Works delivers high performance.



## DAC-X™, Steel for Die-casting Molds with Excellent High-temperature Strength and Toughness

This steel for die-casting molds combines an alloy design that provides high-temperature strength with a unique microstructure control process to achieve both high-temperature strength and toughness. It has excellent heat crack resistance and can extend the life of molds, especially in applications with high thermal load. It also contributes to reduce man-hours for mold repair as well as to improve productivity and quality in high-cycle die-casting products.



## SLD™-f, New Cold Work Die Steel with Excellent Machinability and Toughness

With the diversification in recent demand for molds in the manufacturing of automotive frame components, SLD™-f provides solutions to reduce the total cost of molds by extending the life of molds and shortening the lead time (LT) of production.



## Sialon Ceramics Die Cast Sleeve

Our sialon die cast sleeve consists of two layers: the inner sialon engineering ceramics layer and the outer specialized alloy layer. This product excels at maintaining the temperature of molten metal and achieving stable injection and a longer service life, thus contributing to the improvement of productivity and quality of die casting.



## Electric Discharge Machining [EDM] Wires

Our EDM wires, which are made of carefully selected materials, enable high-speed and high-precision cutting. We offer a wide variety of electrode wires for different applications to meet various needs.



## Friction Stir Welding (FSW) Tools

These FSW tools are manufactured by investment casting of an ultra-high thermal resistance and compressive strength cobalt alloy. They are used to connect different materials including high-tension steel, carbon steel, titanium alloys, aluminum alloys, and magnesium alloys.



■ Chassis



## Industrial Infrastructure-related Field

Aircraft components, power generating equipment-related components, rolling stock components and other industrial equipment are all exposed to severe operating conditions.

Our technologies, quality and product development capabilities, which were developed and proved over many years, have always been bringing innovation.

We will continue to provide high-level reliability and innovation for infrastructure globally.



◀ Related link



# Rolling Stock-related Components

Our cast iron products and soft magnetic materials, as well as our wires and cables, which have long been used for rolling stock, have contributed to railway development locally and globally.



Wires and Cables for Rolling Stock

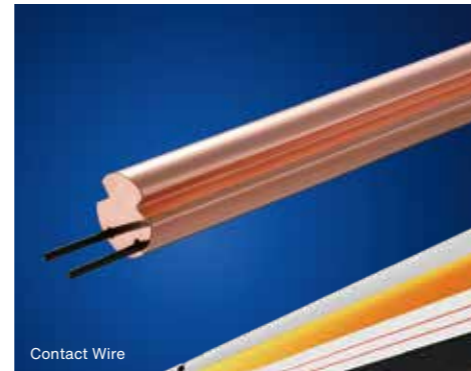

Contact Wire



Rolling Stock



## Joints for Special High-voltage Cables

Metal shielding provides stable insulation performance even in polluted environments, contributing to a consistent supply of power for rolling stock. In addition, since electrical isolation is not required, they offer a high degree of freedom in car installation and help reduce noise during driving.

## Wires and Cables for Rolling Stock/Trolley Wires

Our wires and cables for rolling stock are used in cab wiring, underfloor wiring, wiring between rolling stock and other applications in Shinkansen bullet trains and many other rolling stock vehicles in Japan and overseas. In the railroad sector, we also provide trolley wires, signal cables, LAN cables for high-speed communications, and other products that support power supply and information transmission for railways.



## Ductile Cast iron products for Bogie of Rolling Stock

The products have high low-temperature toughness and dimensional precision. The near net shape and the integrated casting with high shaped flexibility. The weldingless structures help to improve the reliability and reduce the weight.

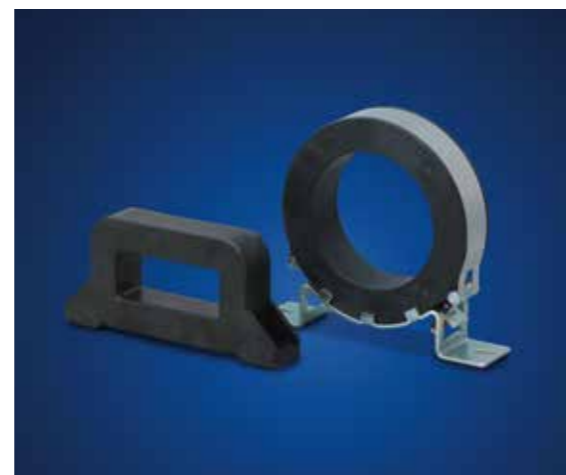

## FINEMET® Common Mode Choke Cores

These common mode choke cores are made of FINEMET® nanocrystalline soft magnetic material. These products furnish high impedance over a broad frequency range and contribute to reducing the size and weight of EMI filters.



## Threaded Pipe Fittings

Our Gourd brand Malleable Iron Pipe Fittings has lived up to its reputation for the excellence in quality and variety of products, which is known the world over, since 1912.



## Category 7 (Cat 7) LAN Cables for High-speed Communications

Our LAN cables deliver the required electrical properties while complying with the European railway fire safety standards. We have accomplished these features by improving the LAN cable structure and adopting a halogen-free sheath material with high flame retardancy, which we have developed ourselves.



## Rodent-proof Optical Cables and LAN Cables

The braided stainless-steel construction makes these cables resistant to rodent damage while maintaining their flexibility. Rodent-proof optical cables are able to support various connectors, making them useful for updating existing facilities. We also have a lineup of rodent-proof LAN cables for devices in equipment rooms and surveillance cameras.

## Materials for Aircraft Components

Our special melting technologies and manufacturing processes, which were developed over many years, deliver materials for aircraft featuring world-class reliability and durability.

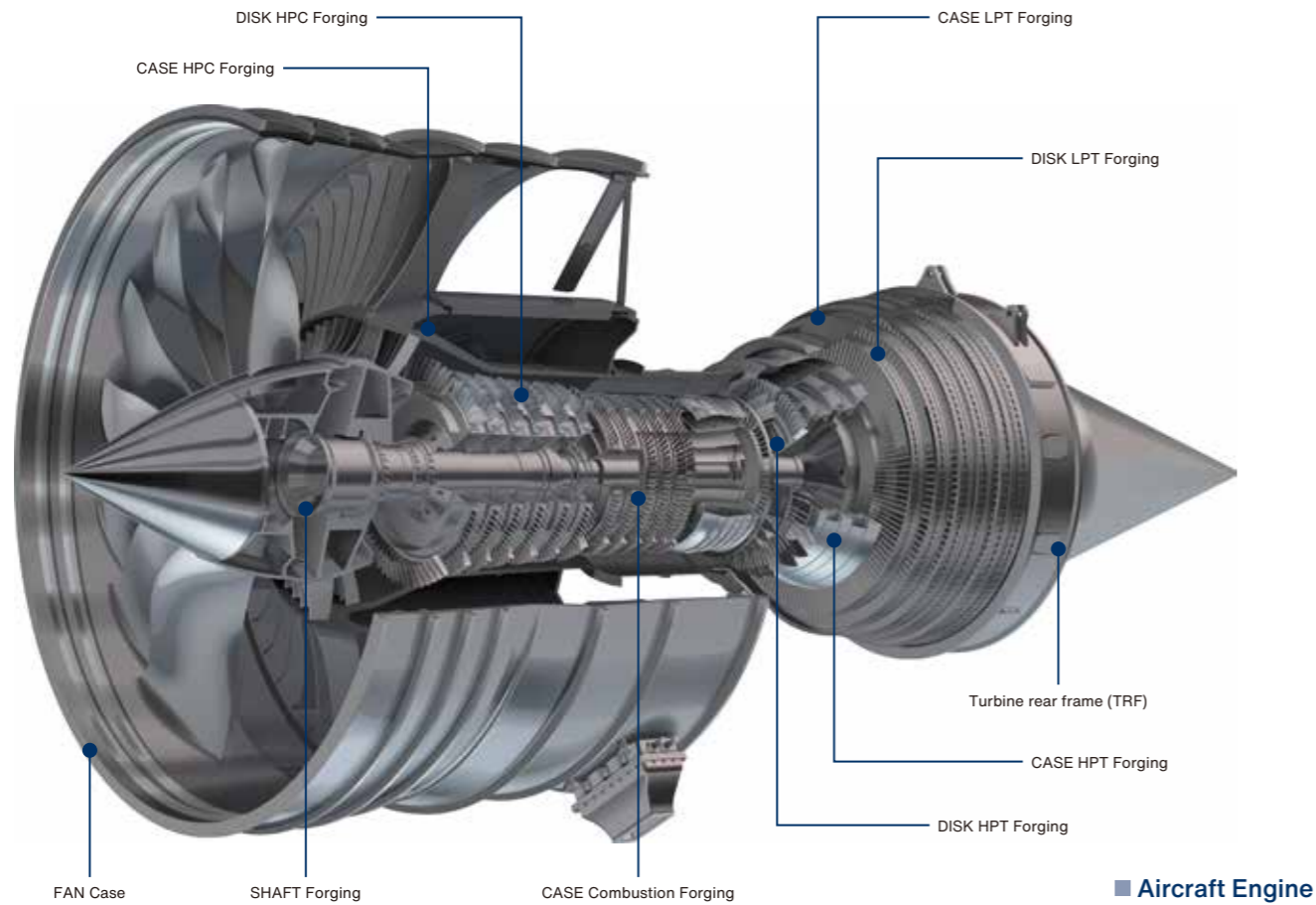

### Materials for Aerospace Engines and Structural Parts

Materials for aerospace engines and structural parts, such as landing gears, must be durable to withstand high-temperature, high-pressure combustion gases, high-speed revolutions, and repetitive heavy loads for an extended period of time. Therefore, such component materials must be highly reliable and durable. Our materials for aerospace components are highly acclaimed and trusted thanks to our special melting technologies and manufacturing processes that have been nurtured over the years.

## Industrial Robot Components

We help to advance industrial robots by offering magnetic materials with world-class properties and distinctive electric wires and cables.



### High-performance Magnets (Neodymium-Iron-Boron Magnets, Ferrite Magnets, Bonded Magnets, Cast Magnets, and Rolled Magnets)

We provide different types of magnets ideal for various applications, including NEOMAX®, a Neodymium-Iron-Boron Magnets with the world's best class magnetic properties, Ferrite Magnets, Bonded Magnets, Cast Magnets, and Rolled Magnets.



### Industrial Robot Cables

The highly flex-resistant and flexible cables are ideal for moving portions of industrial robots, where resistance to repeated bending and twisting and durability are critical requirements. In addition, a wide range of wire and cable products are available to meet many different needs for power supply, control, and signal transmission cables and wires connecting components within and between equipment.



### Linear Motors

To meet diverse requirements including high-precision positioning, constant velocity, and high-speed feeding, we internally design and manufacture various types of linear motors (coreless and iron-core) that provide the driving force for straight-line motion.

# Additive Manufacturing Materials and Precision Forming

Unprecedented products are delivered, based on our expertise in materials and the best of our additive manufacturing technology.



## High Corrosion Resistant and High Strength Alloy ADMUSTER™-C00P

Multi-element alloys are said to be difficult to cast and machine, although they are excellent in strength and corrosion resistance. Proterial developed metal powder made of multi-element alloy by applying laser-powder additive manufacturing and identified process conditions for metal additive manufacturing.

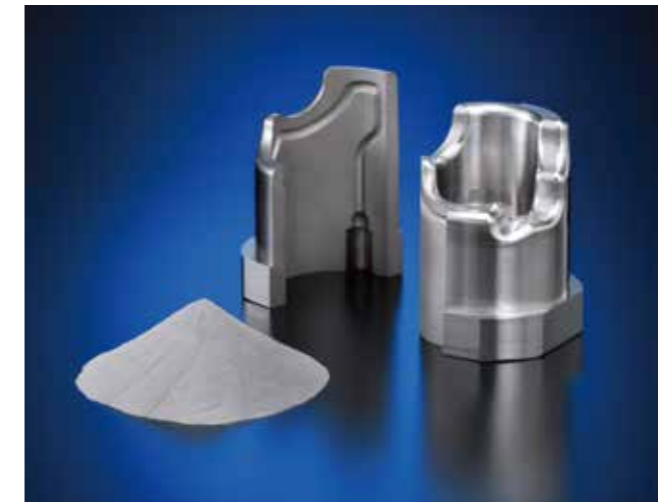

## ADMUSTER™-W285P Low-cobalt Maraging Steel Powder

With a cobalt content of not more than 1%, the material falls outside the scope of specified chemical substances (Group 2 monitoring substances). However, it is as strong as general maraging steel and thus easy to handle in additive manufacturing.



## Metal Additive Prototype Manufacturing Services

We provide molded products with optimal designs that can only be achieved by using metal additive manufacturing (3D printing). In addition to additive manufacturing using our original materials, we also support additive manufacturing using general standard materials.



## High Corrosion Resistance Nickel-based Alloy ADMUSTER™-C21P

This product is a nickel-based alloy with high corrosion resistance, which is enabled through the addition of chromium, molybdenum, and tantalum. The identification of process conditions for the metal additive manufacturing process has enabled us to manufacture near-net-shape components with high corrosion resistance, such as those used in semiconductor manufacturing equipment and chemical plants.



## Hard Particle Dispersion Type Chromium-based Alloy ADMUSTER™-C574P

This hard particle dispersion type chromium-based alloy is excellent in corrosion resistance, resistance to soil abrasion, and workability. When built up with this alloy on the component surface, excavation equipment will have a longer service life and need less maintenance work.



## Metal Powder Injection Moldings (MIM)

The metal injection moldings (MIM) process is a technique to manufacture metal components by injecting metal powder into specific molds. It produces high-density, high-strength sintered components that combine two advantages: the freedom of shape-forming allowed by injection molding and the strength of metal components. The Proterial Group also manufactures products that are among the largest available in the industry.



## Precision Cast Components (Investment Casting)

Proterial is capable of manufacturing near-net-shape cast products that have complex shapes and are widely varied in size, capitalizing on our diverse materials portfolio, unique production technologies, and development capacity.

# Medical and Healthcare-related Components

With our ultra-fine cable, tube and ceramic products, we will help improve the performance of medical devices and contribute to the progress of medical treatment.

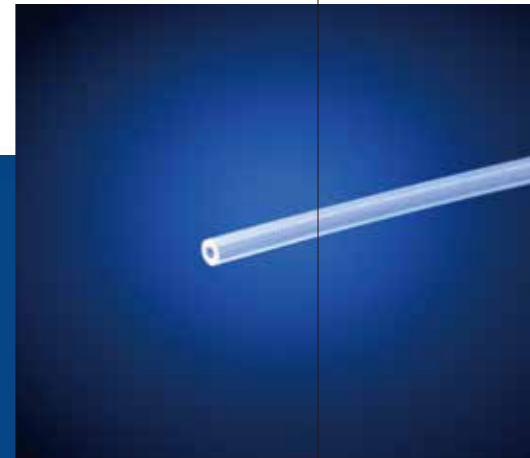

## Tubing for Medical Application

In addition of manufacturing capability of precision extrusion tooling, the experience and extrusion technology for tubing would provide high-end tubing\* for medical application such as vascular access.

\*Including multi-lumen, multi-layer assemblies



## Probe Cables for Ultrasound Diagnostic Equipment

The cable connects the main body of ultrasound diagnostic equipment and the probe used for echo graphic investigation. It is lightweight, excels in elasticity and flexibility, and has high-quality electric characteristics, realizing ease of handling and high-definition images, thereby contributing to the development of medical equipment.

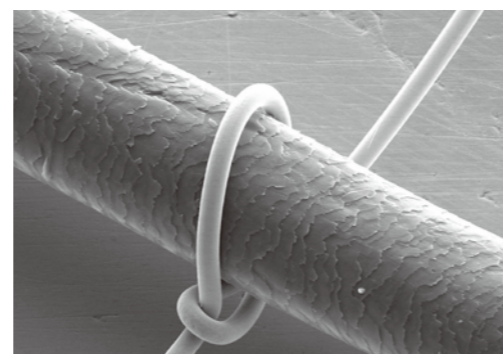

[ 10μm-diameter copper alloy wires and hair ]

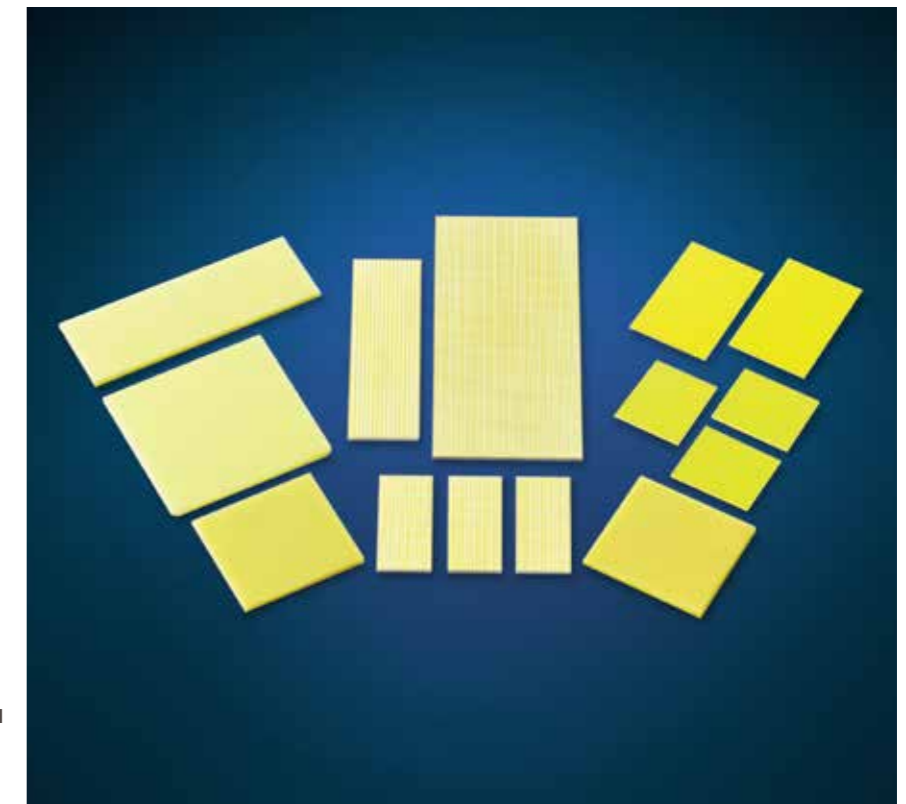

## Ceramic Scintillator Materials

When exposed to radiation, scintillator materials absorb the energy of the radiation and emit visible light. Their high sensitivity and large X-ray absorption coefficient contribute to the reduction of device size. These materials are used in medical equipment such as X-ray CT and analytical instruments. We have also developed a new composite material for security applications.

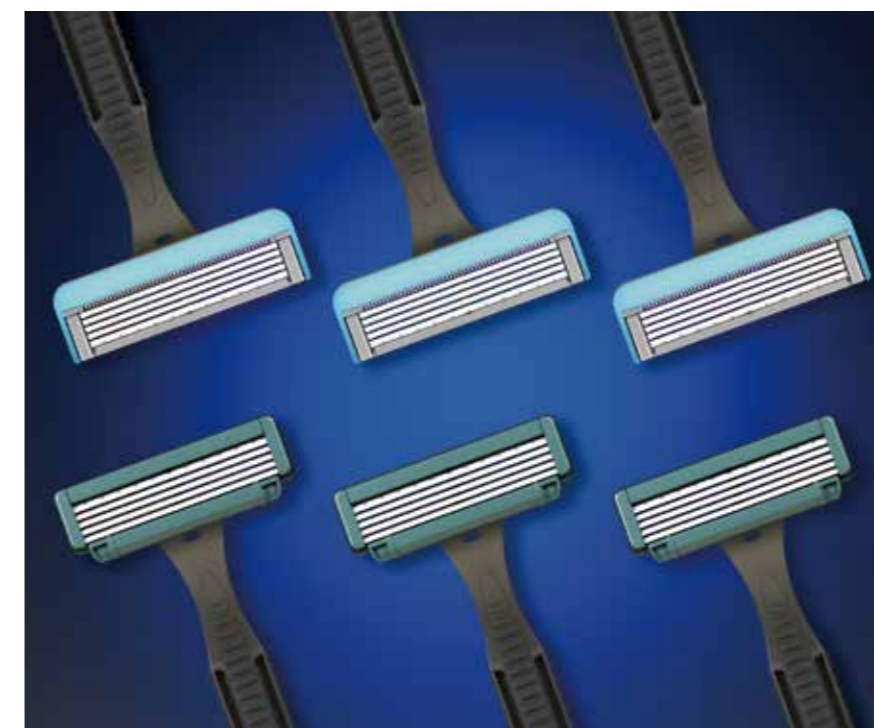

## Razor Blade Materials

These traditional razor blade materials embody our pursuit of the cutting performance of the Japanese sword and sharp cutting edges that will not chip easily. The use of carefully selected raw materials and advanced carbide control technology allow them to continue to evolve technically. Recognizing the high reliability they can bring, we are expanding their applications to surgical knives and other fields.

## Piping Components

Gourd™ brand represents our world top manufacturing quality. Our tough, beautiful and highly workable piping components meet requirements of any piping equipment.



### Polyethylene Gas Piping Systems

Our complete line of products for gas piping systems includes electrofusion (EF) fittings, polyethylene pipes and valves, various transition joints, and EF controllers. Piping systems that use polyethylene pipes are very flexible and typically do not suffer much damage compared to conventional systems that use steel or cast iron pipes when ground displacement occurs due to ground subsidence, earthquakes, frozen ground, etc. Our systems include a wide spectrum of joints and pipes in diameters from 25A to 300A. Characterized by superior corrosion resistance and the exceptional ease with which they can be installed, they contribute to cutting overall installation costs.



### Threaded Pipe Fittings for General Use

Our Gourd™ Malleable Iron Pipe Fittings has lived up to its reputation for the excellence in quality and variety of products, which is known the world over, since 1912.



### Valve Products

We have an extended portfolio of valves including Malleable™ valves. Their materials include stainless, cast and forged steels and polyethylene. Automatic operated valves are also available. Our valves are widely used in manufacturing plants and construction equipment.



### SOFLEX™ Corrugated Stainless Steel Tubes and Fittings (Push Impact™)

SOFLEX™ is the name of our line of flexible stainless steel gas tubes and fittings. They are easy to install and maintain because the tubes require few connections along the way. It also provides highly trusted connection from its unique design.

## Building and Construction Components and Materials

Our construction products support a variety of living and industrial settings through their unique construction methods, technologies and materials.

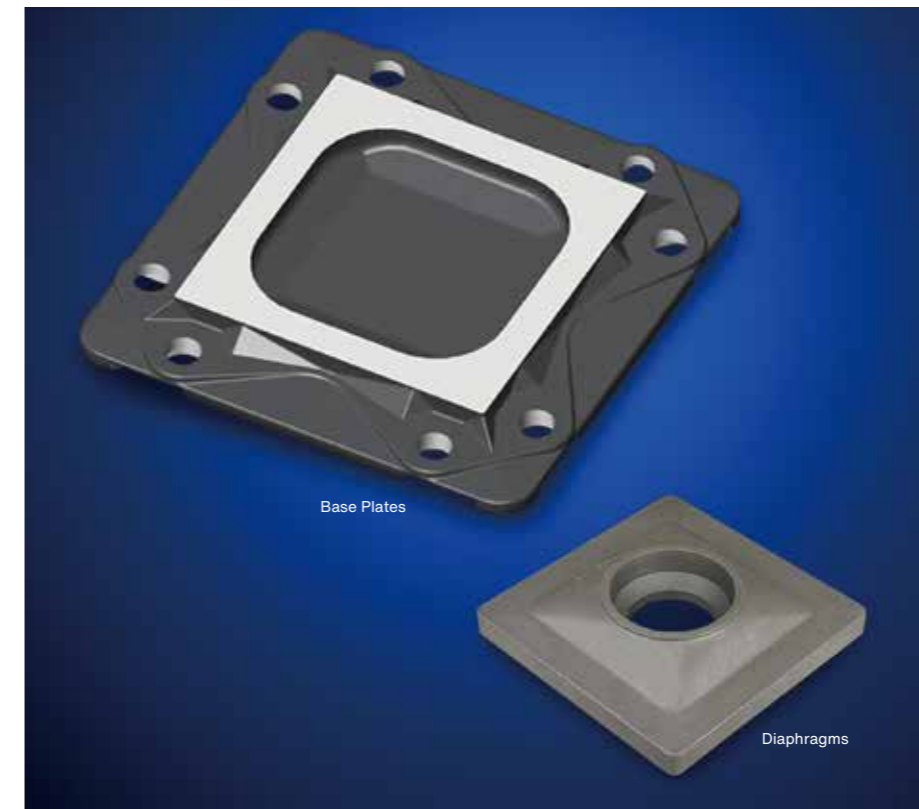

### Base Plates and Diaphragms

These base plates are used as exposed-type fixed column bases to construct steel frame buildings. The highly workable column bases provide superior earthquake resistance, significantly shorter work periods, and reduced installation space.

Our diaphragms are used in a beam-column joint that connects upper and lower story columns of different width. We run a production line dedicated to volume manufacturing to meet shorter delivery times.



### Flexible Cables

Cables with superior flexibility are used to supply power and signals to cranes and hoists inside plants (supplemental equipment for cranes). Since they are also durable enough to be used in harsh environments, these cables are expected to play a role in mining and other areas of the resource extraction sector.



### MLFC™ Flame-retardant Polyflex Insulated Wires

MLFC™ flame-retardant polyflex insulated wire has been widely used for electric wiring, including insulated wire inside switchboards and motor lead wires, because of its outstanding heat resistance, flame-retardant properties, and flexibility.

# Facility Equipment and Components

Our technologies, developed in many different fields, help create products with unique features.



## SAM™ and Aera™ Mass Flow Controllers

Mass flow controllers are devices that precisely control the volume of gas flowing within a gas supply system used for deposition and etching in a semiconductor manufacturing line. Our products are featured with a waveform diaphragm made of our proprietary Ni-Co alloy installed within the valve. They have clean structures in which the parts that come in contact with gases are equipped with metal seals, and we have a complete lineup suited to a range of purposes. We continue to release digital mass flow controllers that address the requirements of the ever-evolving semi-conductor process in order to contribute to further advance of semiconductor manufacturing technologies.



## Rolls for Steel Mills

Our rolls for steel rolling mills have higher strength and wear resistance, and enable more efficient production of high-precision rolled products. A wide variety of products are available to manufacture steel plates, pipes, bars, and wires, as well as other shaped steels, to meet diverse demands from steelmakers. Most notably, our HINEX™ products, which were the first commercially available high-speed steel-based composite rolls in the world, and other high-speed steel composite rolls have significantly better rolling performance than traditional rolls and help improve rolling productivity and quality.



## Cylinders and Screws for Plastic Molding Machines

The H-ALOY™ cylinders lined with nickel- or cobalt-based alloy and the high-performance YPT™ screws are designed for plastic molding machines. With excellent resistance to abrasion and corrosion, both products, when used together, help to stabilize the operation of the plastic molding process.



## Closed Type Diaphragm Expansion Tanks

Our closed type diaphragm expansion tank loses less thermal energy. Our closing systems eliminate potential intrusion of dust or foreign materials from outside of system and maintain high level of cleanliness. Less oxygen is supplied to the systems, which reduce chance of corrosion within piping.



## Blade Materials

Proterials' blade materials date back to the "Tatara" method, a traditional ironmaking technique that Japan can proudly stand behind. For their Japanese sword-like cutting performance and superior resistance to edge chipping, our blade materials are well received by professional users, especially artisans. Our representative cutlery steel brands include Shirogami™, Kigami™, Aogami™, Gingami™, and ATS™34.



The large SPring-8 synchrotron radiation facility and SACLA, an adjacent X-ray Free Electron Laser (XFEL) facility (Photo credit: RIKEN)

## Undulators

We supply undulators to SPring-8, a large synchrotron radiation facility capable of producing the most powerful synchrotron radiation in the world, and SACLA, an adjacent X-ray Free Electron Laser (XFEL) facility. To generate synchrotron radiation, magnets are used to change the path of electrons that have been accelerated to nearly the speed of light. Extremely bright and highly directional synchrotron radiation contributes to wide-ranging research in everything from nanotechnology and biotechnology to industrial applications.



## Solenoids

The products are widely used to control valves in hydraulic machines in such fields as construction, agriculture, and industrial machinery and vehicles. Our broad lineup of solenoids, including proportional and on/off types, are available with high sucking force, high pressure resistance, and a waterproofing property, contributing to the advancement of hydraulic equipment.

## Power Generating Equipment-related Components

Our high-quality products meet requirements of diversified power generation technologies: thermal, wind and photovoltaic.



Turbine Blade

### Turbine Blade Materials

Turbine blades rotate at very high speeds and are vital components that need to be durable to withstand extreme conditions such as exposure to high temperature steam. As such, they must be strong at high temperatures, have a high degree of fracture toughness, and be reliable in terms of quality. We provide reliable products by utilizing our integrated manufacturing system, which draws upon our broad expertise and the latest technologies, helping our customers generate power more efficiently.



### Amorphous Alloys Metglas®

This material is used in the cores of distribution transformers, such as those mounted on utility poles, and in cut cores for reactors built into power conditioner systems for solar photovoltaic, wind power, and other renewable energies. When the core material is changed from magnetic steel sheets to amorphous alloy, no-load loss (standby power consumption) in the core reduces, resulting in higher efficiency and greater power savings. Demand is growing for this product for its recognition as a material effective for reducing CO<sub>2</sub> emissions, which is essential for mitigating global warming. With the low-loss MaDC-A™ series added to the portfolio, Metglas® is expected to find wider applications in Japan and abroad.

**Metglas**



Transformer Core

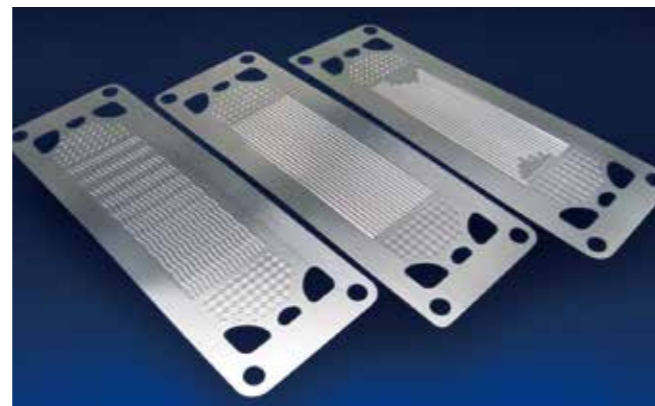

### ZMG™232G10 for Solid Oxide Fuel Cell (SOFC) Interconnects

This material, made of a ferrite alloy consisting primarily of iron and chrome, is used in interconnects that electrically link cells in SOFCs. It has oxidation resistance over long periods, has good conductivity in high-temperature environments, and achieves nearly the same thermal expansion coefficient as that of electrode materials.

## Telecommunication Infrastructure Components

We will offer various products and solutions to mobile station bases and data centers.



### PrimeStar™ VCI Remote Monitoring System for Fiber-optic Lines

Our optical fiber products are critical components of the patented low-loss optic connection technology. The technologies support highly reliable optical fiber monitoring system, PrimeStar VCI, required for important data communication services in financial and broadcasting businesses. They also simplify monitoring and maintenance processes, and contributes to improving efficiency and labor saving of wiring and maintenance activities, which are indispensable in the data center.

PrimeStar™ VCI



### Wireless Base Station Isolators/Circulators

These components are designed to stabilize the operation of the amplifier that regulates audio during communications and to prevent cross-modulation. Using internally developed high-performance ferrite magnets and low-loss garnets, these isolators and circulators enable size and weight reductions and are compatible with next-generation (5G) network specifications.



### AITiC Substrates for Thin Film Magnetic Heads

These substrates are used in thin film magnetic heads for hard drives. They have made it possible to provide the properties required for highly precise data scanning, contributing to larger capacity drives that are more reliable.

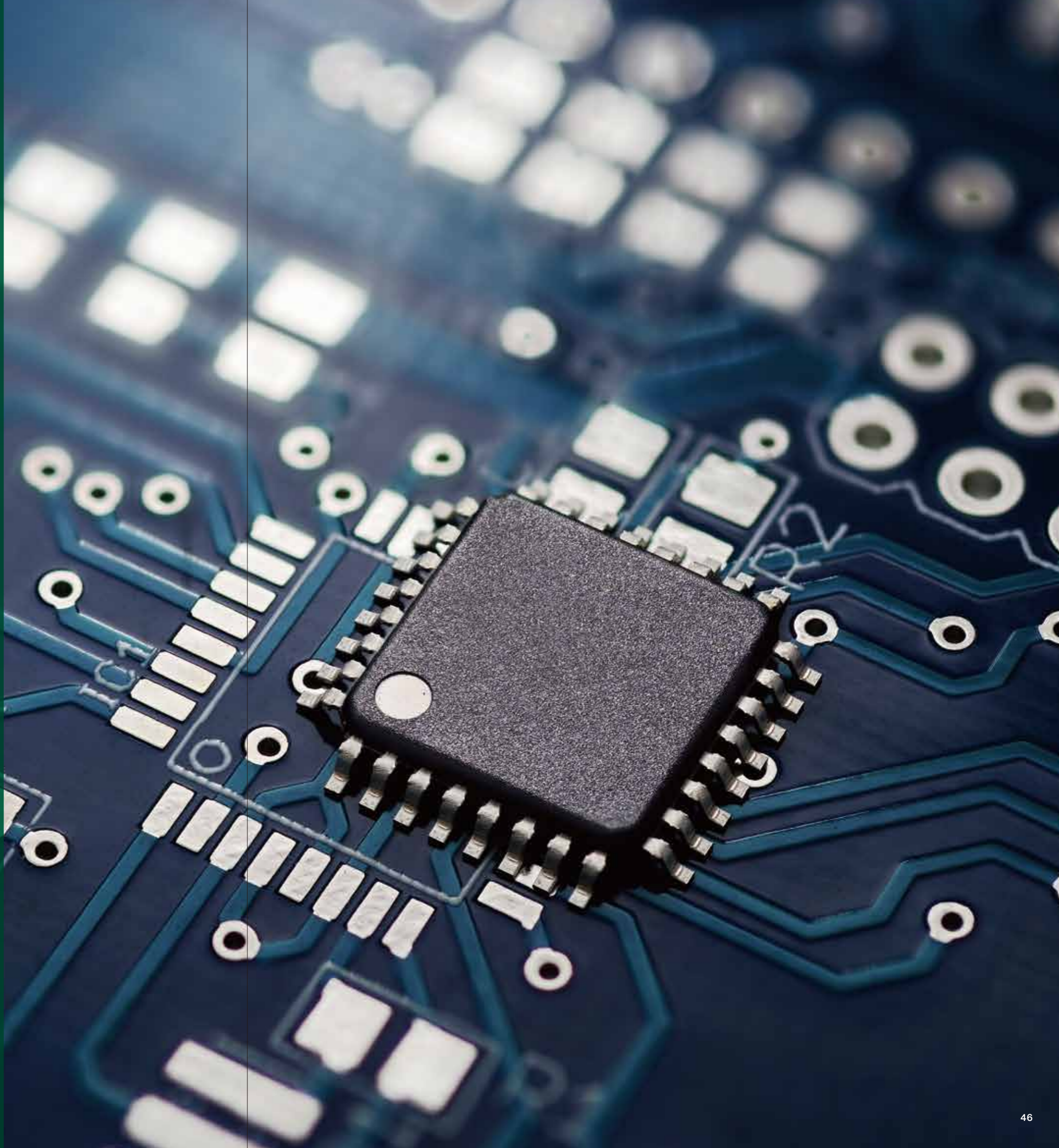

## Electronics-related Field

The fields of video/IT equipment, home appliances, and electronic devices are constantly evolving.

Our production system, encompassing the entire process from prototyping to commercialization and mass production, allows us to meet our customers' diverse needs.

We will continue to support the growth of society at large with high-performance components and materials.



◀ Related link



## IT and Home Appliance-related Components

Proterial offers alloys for electronic products and magnetic materials with outstanding properties to contribute to the evolution of flat displays and mobile terminals.

### Materials for Organic Electroluminescent Panels

These materials are used for the metal masks needed to produce organic electroluminescent display backboards and panels. They are available in the form of thin sheets that restrict thermal expansion deformation, produced by our control technology of alloy composition and cold rolling technology developed over the years. We also offer high-strength stainless steels used for the back panels of foldable devices.



### Clad Metals for Heat Spreaders

These clad metals combine stainless steel and copper to achieve both high strength and high thermal conductivity. They are useful for reducing the thickness, weight, and the number of components of mobile devices, such as smartphones and tablets.



### High-Performance Magnets (Neodymium-Iron-Boron Magnets, Ferrite Magnets, Bonded Magnets, Cast Magnets, and Rolled Magnets)

We provide different types of magnets ideal for various applications, including NEOMAX®, a Neodymium-Iron-Boron Magnets with the world's best class magnetic properties, Ferrite Magnets, Bonded Magnets, Cast Magnets, and Rolled Magnets.

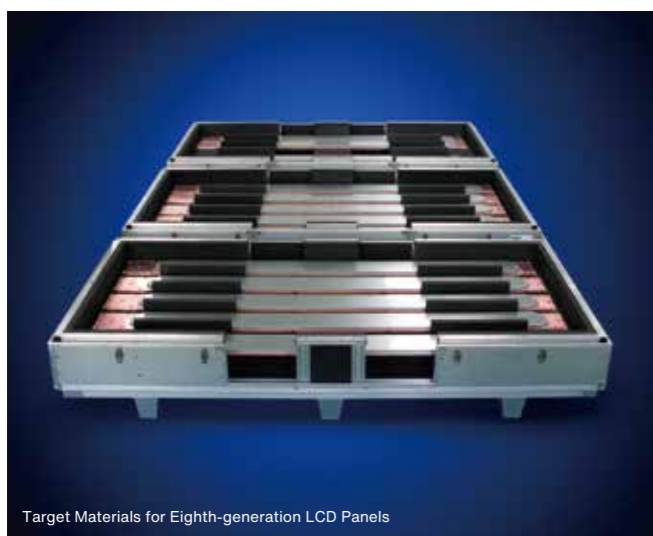

### Sputtering Target Materials for LCDs

The Sputtering Target materials are used for thin film interconnects of LCDs. Our HIP (Hot Isostatic Press) method enables to obtain fine and homogeneous structure, which corresponds to the requirement of increasing in size. Furthermore, our alloy design technology enables to provide various alloy materials as usage, which responds to the requirement like high heat resistance, and high moisture-resistance.



### Lead Frame Materials

We provide an extensive lineup of iron nickel-based and copper-based lead frame materials; materials for logic families and power semiconductors, and dual gauge copper strips which has a multi thickness design in width direction.

# Electronic Device-related Components

Soft magnetic materials with unique features allow us to make electronic devices smaller and more energy-efficient.



## FINEMET® Nanocrystalline Magnetic Alloys

FINEMET® is the world's first nanocrystalline soft magnetic alloy developed by Proterial. This new Fe-based soft magnetic alloy is composed of nanocrystals. It has high saturation induction, high permeability, excellent temperature characteristics and temporal stability. FINEMET® is utilized in high-frequency power transformers, noise-suppression components and other applications where it contributes to downsizing and lightening.



## Amorphous Powder Cores/Coils

These cores and coils are designed to combine high saturation flux density and low loss by using a Fe-based amorphous metal powder. They are suitable for smoothing choke coils for both input and output of power supply, choke coils for normal-mode noise reduction, and choke coils for power factor correction circuits. The coils are able to operate at frequencies as high as 100 kHz and contribute to making equipment smaller and more efficient.



## Soft Ferrite Cores

Although these cores have a lower saturation flux density than other soft magnetic materials, their electrical resistance is higher, and they are characterized by overwhelmingly excellent magnetic properties in high-frequency bands from 100 kHz to several tens of MHz. With the addition of the MaDC-F™ series, which have low losses in the high-frequency range, these products help to make passive components smaller, lighter, and more efficient in many fields, including xEV, mobile devices, and industrial equipment.



## Cut Cores

Used in medium-frequency power transformers and choke coils, our cut cores contribute to higher efficiency and smaller sizes. FINEMET® nanocrystalline magnetic materials and amorphous metal products suited to various uses are available.



## FINEMET® Common Mode Choke Cores and Coils

Instilled with high magnetic permeability and low Q factors, these cores and coils furnish high impedance over a broad frequency range, allowing them to manifest major noise suppression effects. Moreover, because impedance does not vary widely by temperature, stable noise suppression effects can be obtained over a broad temperature range.

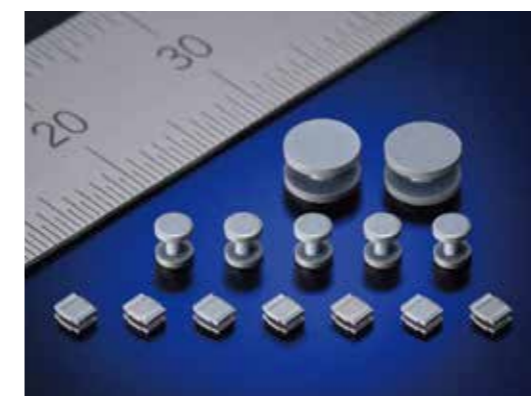

## Metal Powder Core HRM Series

The products have about three times the saturation magnetic flux density and almost twice the radial crushing strength of Ni-Zn ferrite products, which were conventionally used. These characteristics make them relatively superior in electrical resistance, rustproofing, and reliability (e.g., temperature stability) among metallic materials. Serving as cores for power inductors embedded in various information equipment and automotive electrical equipment, they contribute to smaller and higher-current inductors (improvement of DC superimposition properties).



## FM SHIELD™ Magnetic Shield Sheets

The product consists of laminated FINEMET® nanocrystalline soft magnetic material ribbon and polyethylene terephthalate film. The shield sheet protects electronic devices from electromagnetic noise and provides robust shield in shield boxes or rooms within buildings exposed to environmental magnetic fields like electric power distribution facilities.



## FINEMET® Multilayered Sheets

These shield yoke sheets are used in wireless chargers for smartphones, tablet PCs, and other communications devices. The lamination processing of FINEMET®, a high magnetic permeability material with low core loss, enables a slimmer size and lighter weight and achieves impressive cuts in power transmission noise and energy loss.